

Photocouplers LTV-3150 series

1.0 Amp Output Current IGBT Gate Drive Optocoupler with Rail-to-Rail Output Voltage, High CMR.

1. DESCRIPTION

The LTV-3150 optocoupler is ideally suited for driving power IGBTs and MOSFETs used in motor control inverter applications and inverters in power supply system. It contains an AlGaAs LED optically coupled to an integrated circuit with a power output stage. The 1.0A peak output current is capable of directly driving most IGBTs with ratings up to 1200 V/50 A. For IGBTs with higher ratings, the LTV-3150 series can be used to drive a discrete power stage which drives the IGBT gate.

The Optocoupler operational parameters are guaranteed over the temperature range from $-40^{\circ}\text{C} \sim +105^{\circ}\text{C}$.

1.1 Features

- 1.0 A maximum peak output current
- Rail-to-rail output voltage
- 200 ns maximum propagation delay
- 100 ns maximum propagation delay difference
- 20 kV/us minimum Common Mode Rejection (CMR) at $V_{CM} = 1500\text{ V}$
- $I_{CC} = 3.0\text{ mA}$ maximum supply current
- Wide operating range: 15 to 30 Volts (V_{CC})
- Guaranteed performance over temperature $-40^{\circ}\text{C} \sim +105^{\circ}\text{C}$.
- MSL Level 1
- Safety approval:
 - UL/ cUL Recognized 5000 $V_{RMS}/1\text{ min}$
 - IEC/EN/DIN EN 60747-5-5 $V_{IORM} = 630\text{ Vpeak}$

1.2 Applications

- IGBT/MOSFET gate drive
- Uninterruptible power supply (UPS)
- Industrial Inverter
- AC/Brushless DC motor drives

Functional Diagram

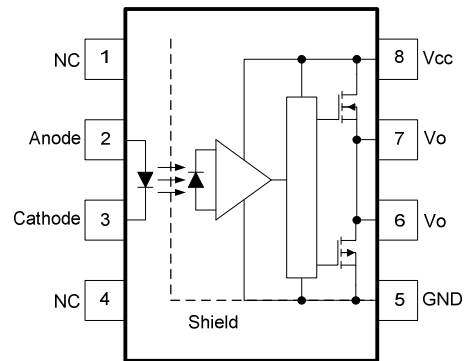

A $0.1\mu\text{F}$ bypass Capacitor must be connected between Pin 5 and 8.

Truth Table

LED	V_{CC-GND} (Turn-ON, +ve going)	V_{CC-GND} (Turn-OFF, -ve going)	V_o
OFF	0 - 30 V	0 - 30 V	Low
ON	0 - 11.0 V	0 - 9.5 V	Low
ON	11.0 - 13.5 V	9.5 - 12 V	Transition
ON	13.5 - 30 V	12 - 30 V	High

Photocouplers LTV-3150 series

2. PACKAGE DIMENSIONS

2.1 LTV-3150

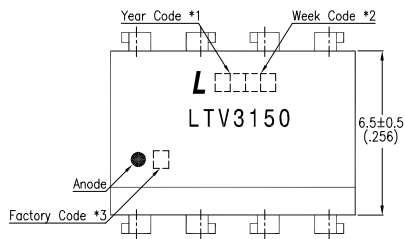

2.2 LTV-3150M

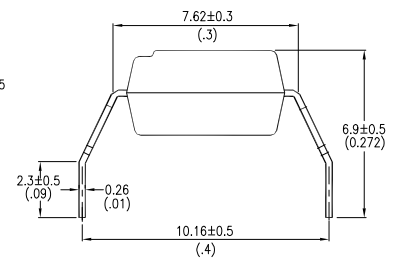
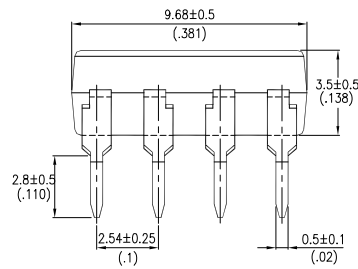
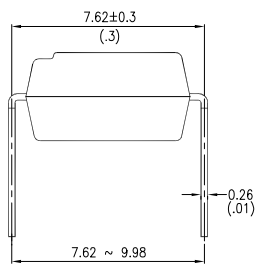
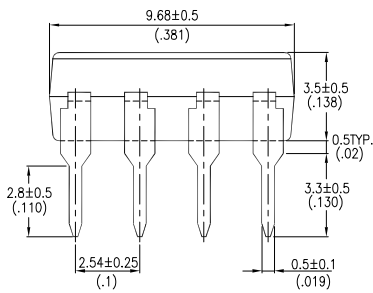
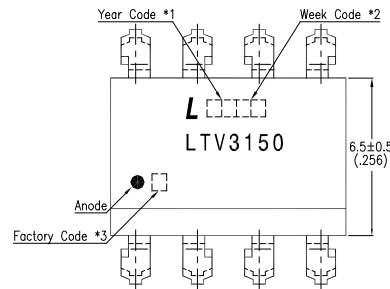

2.3 LTV-3150S

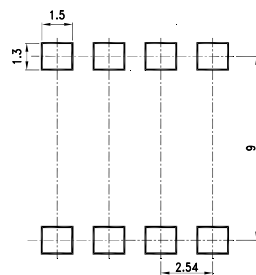
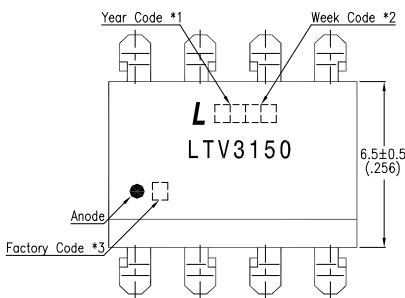

Notes :

- *1. Year date code.
- *2. 2-digit work week.
- *3. Factory identification mark
(Y : Thailand).

Dimensions are in Millimeters and (Inches).

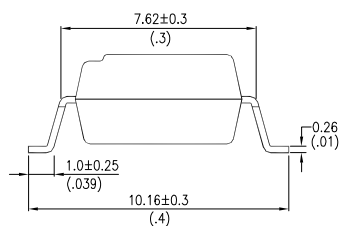
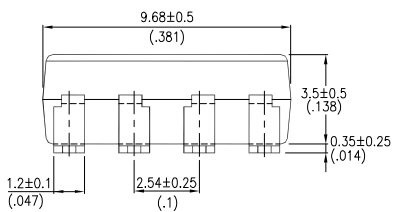

Photocouplers LTV-3150 series

3. TAPING DIMENSIONS

3.1 LTV-3150S-TA

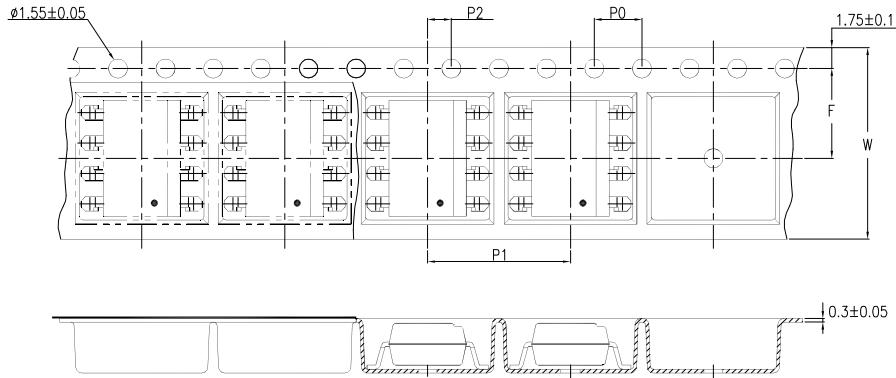

3.2 LTV-3150S-TA1

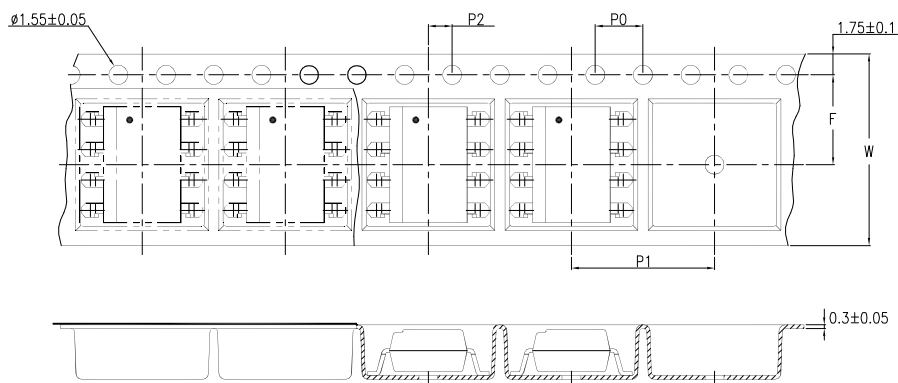

Description	Symbol	Dimension in mm (inch)
Tape wide	W	16 ± 0.3 (0.63)
Pitch of sprocket holes	P_0	4 ± 0.1 (0.15)
Distance of compartment	F	7.5 ± 0.1 (0.295)
	P_2	2 ± 0.1 (0.079)
Distance of compartment to compartment	P_1	12 ± 0.1 (0.47)

3.3 Quantities Per Reel

Package Type	LTV-3150
Quantities (pcs)	1000

Photocouplers LTV-3150 series

4. RATING AND CHARACTERISTICS

4.1 Absolute Maximum Ratings

Parameter	Symbol	Min	Max	Unit	Note
Storage Temperature	T_{stg}	-55	+125	°C	—
Operating Temperature	T_{opr}	-40	+105	°C	—
Output IC Junction Temperature	T_J	—	125	°C	—
Total Output Supply Voltage	$(V_{CC} - V_{EE})$	0	35	V	—
Average Forward Input Current	I_F	—	25	mA	—
Reverse Input Voltage	V_R	—	5	V	—
Peak Transient Input Current	$I_{F(TRAN)}$	—	1.0	A	1
“High” Peak Output Current	$I_{OH(PEAK)}$	—	1.0	A	2
“Low” Peak Output Current	$I_{OL(PEAK)}$	—	1.0	A	2
Input Current (Rise/Fall Time)	$t_{r(IN)} / t_{f(IN)}$	—	500	ns	3
Output Voltage	$V_{O(PEAK)}$	—	V_{CC}	V	—
Power Dissipation	P_I	—	45	mW	—
Output IC Power Dissipation	P_O	—	250	mW	—
Total Power Dissipation	P_T	—	295	mW	—
Lead Solder Temperature	T_{sol}	—	260	°C	—

Note: Ambient temperature = 25°C, unless otherwise specified. Stresses exceeding the absolute maximum ratings can cause permanent damage to the device. Exposure to absolute maximum ratings for long periods of time can adversely affect reliability.

Note: Note: A ceramic capacitor (0.1 μF) should be connected between pin 8 and pin 5 to stabilize the operation of a high gain linear amplifier. Otherwise, this Photocoupler may not switch properly. The bypass capacitor should be placed within 1 cm of each pin.

Note 1: Pulse width (PW) ≤ 1 μs, 300 pps

Note 2: Exponential waveform. Pulse width ≤ 0.3 μs, f ≤ 15 kHz

Note 3: The rise and fall times of the input on-current should be less than 500 ns

4.2 Recommended Operating Conditions

Parameter	Symbol	Min	Max	Unit
Operating Temperature	T_A	-40	105	°C
Supply Voltage	V_{CC}	15	30	V
Input Current (ON)	$I_{FL(ON)}$	7	16	mA
Input Voltage (OFF)	$V_{F(OFF)}$	-3.0	0.8	V

Photocouplers LTV-3150 series

4.3 ELECTRICAL OPTICAL CHARACTERISTICS

	Parameter	Symbol	Min.	Typ.	Max.	Unit	Test Condition	Figure	Note
Input	Input Forward Voltage	V_F	1.2	1.37	1.8	V	$I_F = 10\text{mA}$	13	—
	Input Forward Voltage Temperature Coefficient	$\Delta V_F / \Delta T$	—	-1.237	—	mV/°C	$I_F = 10\text{mA}$	—	—
	Input Reverse Voltage	BV_R	5	—	—	V	$I_R = 10\mu\text{A}$	—	—
	Input Threshold Current (Low to High)	I_{FLH}	—	1.9	5	mA	$V_O > 5\text{V}, I_O = 0\text{A}$	6, 7, 18	—
	Input Threshold Voltage (High to Low)	V_{FHL}	0.8	—	—	V	$V_O < 5\text{V}, I_O = 0\text{A}$	—	—
	Input Capacitance	C_{IN}	—	33	—	pF	$f = 1\text{MHz}, V_F = 0\text{V}$	—	—
Output	High Level Supply Current	I_{CCH}	—	1.9	3.0	mA	Output Open, $I_F = 7\text{ to }16\text{mA}$	4, 5	—
	Low Level Supply Current	I_{CCL}	—	2.0	3.0	mA	Output Open, $V_F = -3\text{ to }+0.8\text{V}$		—
	High level output current	I_{OH}	—	—	-0.3	A	$V_O = (V_{CC} - 1.5\text{V})$	16	1
			—	—	-0.8		$V_O = (V_{CC} - 3\text{V})$		2
	Low level output current	I_{OL}	0.3	—	—	A	$V_O = (V_{EE} + 1.5\text{V})$	17	1
			0.8	—	—		$V_O = (V_{EE} + 3\text{V})$		2
	High level output voltage	V_{OH}	$V_{CC} - 0.6$	$V_{CC} - 0.35$	—	V	$I_F = 10\text{mA}, I_O = -100\text{mA}$	1, 2, 14	—
	Low level output voltage	V_{OL}	—	$V_{EE} + 0.25$	$V_{EE} + 0.4$	V	$I_F = 0\text{mA}, I_O = 100\text{mA}$	3, 15	—
	UVLO Threshold	V_{UVLO+}	11.0	12.5	13.5	V	$V_O > 5\text{V}, I_F = 10\text{mA}$	19	—
V_{UVLO-}		9.5	10.9	12.0	V	$V_O < 5\text{V}, I_F = 10\text{mA}$	—		
UVLO Hysteresis	$UVLO_{HYS}$	—	1.6	—	V		—		

All Typical values at $T_A = 25^\circ\text{C}$ and $V_{CC} - V_{EE} = 15\text{ to }30\text{V}$, unless otherwise specified; all minimum and maximum specifications are at recommended operating condition. (Refer to 4.2)

Note 1: Maximum pulse width = 50 μs .

Note 2: Maximum pulse width = 10 μs .

Photocouplers LTV-3150 series

5. SWITCHING SPECIFICATION

Parameter	Symbol	Min.	Typ.	Max.	Unit	Test Condition	Figure	Note
Propagation Delay Time to High Output Level	t_{PLH}	50	120	200	ns	$R_g = 47\Omega$, $C_g = 3nF$, $f = 10\text{ kHz}$, Duty Cycle = 50% $I_F = 7\text{ to }16\text{ mA}$, $V_{CC} = 15\text{ to }30V$ $V_{EE} = \text{ground}$	8, 9, 10, 11, 12, 20	—
Propagation Delay Time to Low Output Level	t_{PHL}	50	110	200				—
Pulse Width Distortion	PWD	—	15	70				—
Propagation delay difference between any two parts or channels	PDD	-100	—	100			3	
Output Rise Time (20 to 80%)	T_r	—	35	—			20	—
Output Fall Time (80 to 20%)	T_f	—	35	—				—
UVLO turn on delay	$T_{UVLO\ ON}$	—	1.6	—	μs	$I_F = 10\text{ mA}$, $V_O > 5\text{ V}$	—	
UVLO turn off delay	$T_{UVLO\ OFF}$	—	0.4	—		$I_F = 10\text{ mA}$, $V_O < 5\text{ V}$	—	
Common mode transient immunity at high level output	$ CMH $	20	25	—	$kV/\mu s$	$T_A = 25^\circ C$, $I_F = 10\text{ to }16\text{ mA}$, $V_{CM} = 1500\text{ V}$, $V_{CC} = 30\text{ V}$	21	1
Common mode transient immunity at low level output	$ CML $	20	25	—		$T_A = 25^\circ C$, $V_F = 0\text{ V}$, $V_{CM} = 1500\text{ V}$, $V_{CC} = 30\text{ V}$		2

All Typical values at $T_A = 25^\circ C$ and $V_{CC} - V_{EE} = 15\text{ to }30\text{ V}$, unless otherwise specified; all minimum and maximum specifications are at recommended operating condition. (Refer to 4.2)

Note 1: CM_H is the maximum rate of rise of the common mode voltage that can be sustained with the output voltage in the logic high state ($V_O > 15\text{ V}$).

Note 2: CM_L is the maximum rate of fall of the common mode voltage that can be sustained with the output voltage in the logic low state ($V_O < 1\text{ V}$).

Note 3: The difference between t_{PHL} and t_{PLH} between any two parts series parts under same test conditions.

Photocouplers LTV-3150 series

6. ISOLATION CHARACTERISTIC

Parameter	Symbol	Min.	Typ.	Max.	Unit	Test Condition	Note
Withstand Insulation Test Voltage	V_{ISO}	5000	—	—	V	$RH \leq 40-60\%$, $t = 1\text{min}$, $T_A = 25^\circ\text{C}$,	1, 2
Input-Output Resistance	R_{I-O}	—	10^{12}	—	Ω	$V_{I-O} = 500\text{V DC}$	1
Input-Output Capacitance	C_{I-O}	—	0.90	—	pF	$f = 1\text{MHz}$, $T_A = 25^\circ\text{C}$	1

All Typical values at $T_A = 25^\circ\text{C}$ unless otherwise specified. All minimum and maximum specifications are at recommended operating condition. (Refer to 4.2)

Note 1: Device is considered a two terminal device: pins 1, 2 and 3 are shorted together and pins 4, 5 and 6 are shorted together.

Note 2: According to UL1577, each photocoupler is tested by applying an insulation test voltage $6000V_{RMS}$ for one second (leakage current less than $10\mu\text{A}$). This test is performed before the 100% production test for partial discharge

Photocouplers LTV-3150 series

7. TYPICAL PERFORMANCE CURVES & TEST CIRCUITS

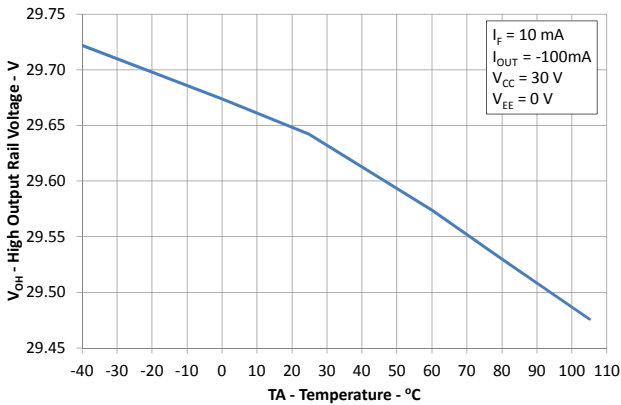

Figure 1: High output rail voltage vs. Temperature

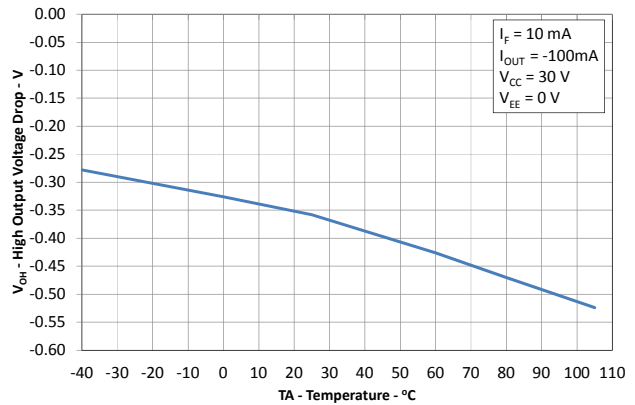

Figure 2: V_{OH} vs. Temperature

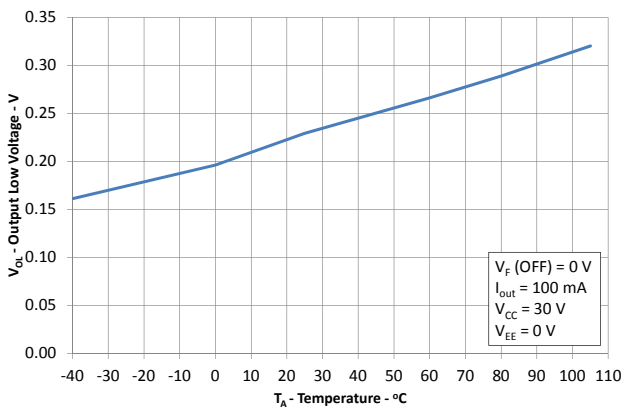

Figure 3: V_{OL} vs. Temperature

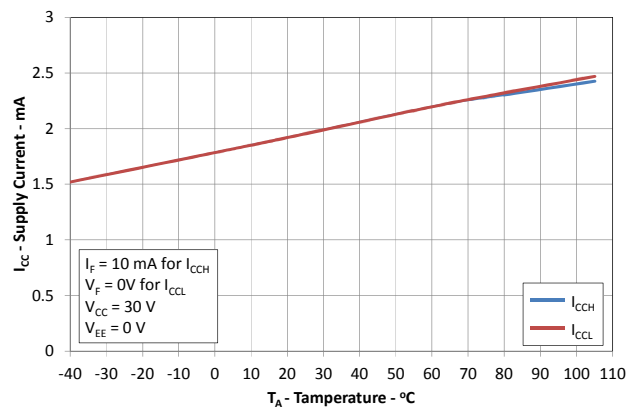

Figure 4: I_{CC} vs. Temperature

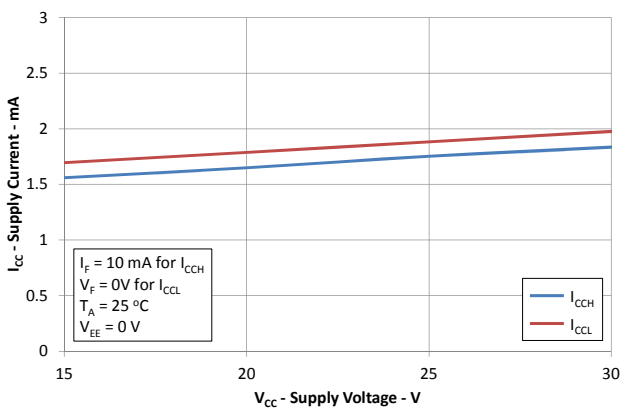

Figure 5: I_{CC} vs. V_{CC}

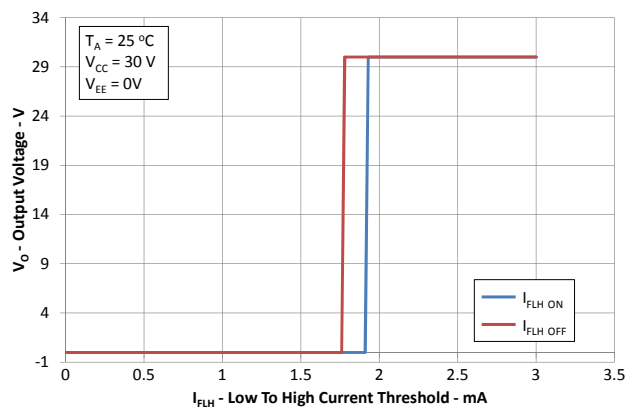

Figure 6: IFLH hysteresis

Photocouplers LTV-3150 series

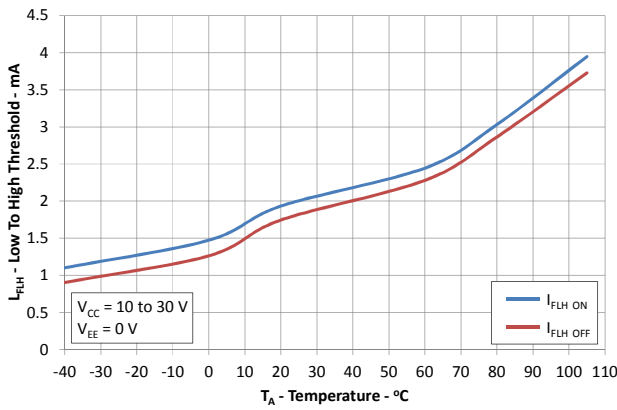

Figure 7: I_{FLH} vs. Temperature

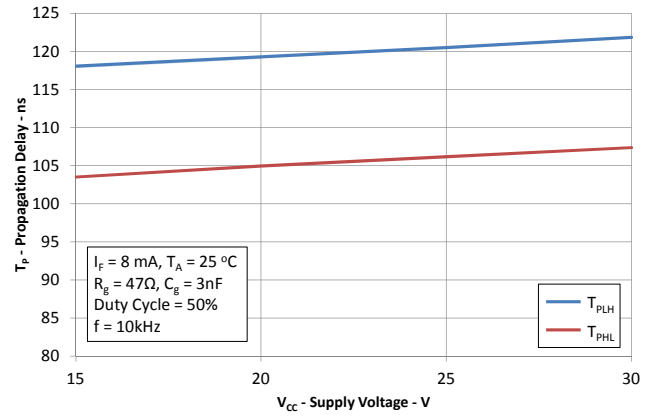

Figure 8: Propagation delays vs. V_{CC}

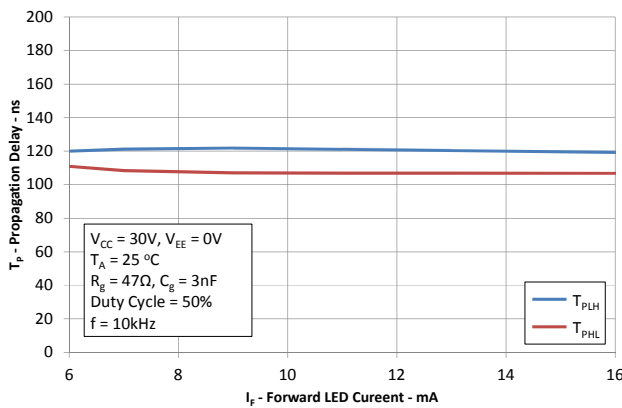

Figure 9: Propagation delays vs. I_F

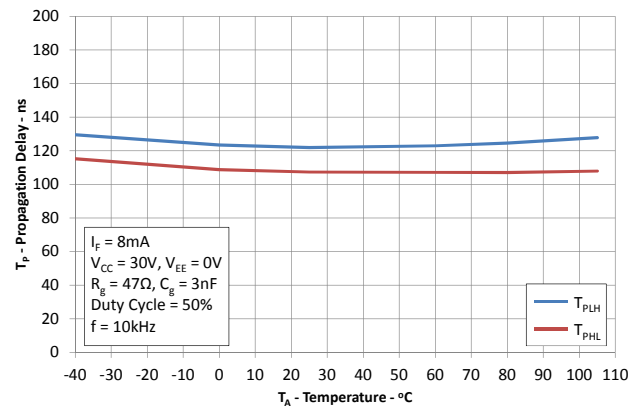

Figure 10: Propagation delays vs. Temperature

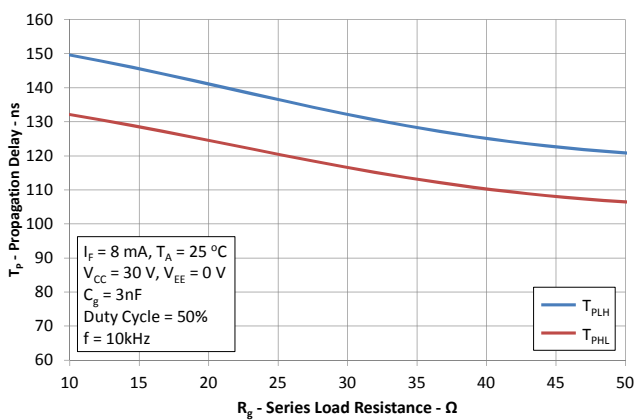

Figure 11: Propagation delays vs. R_g

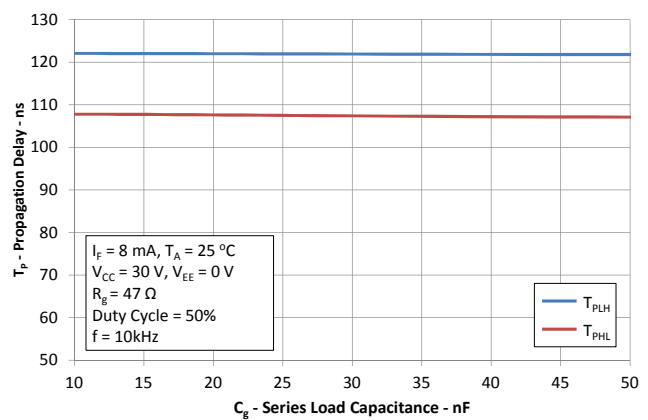

Figure 12: Propagation delays vs. C_g

Photocouplers LTV-3150 series

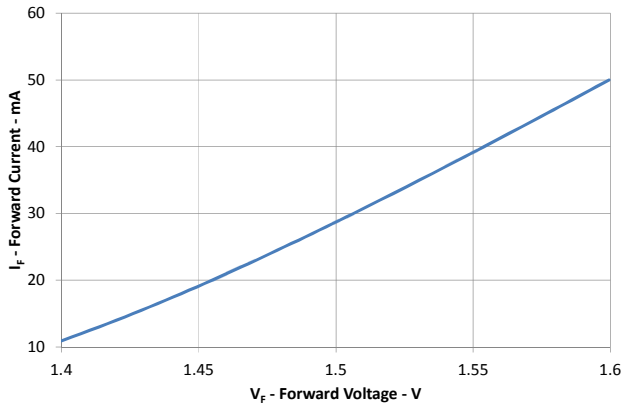

Figure 13: Input current vs. Forward voltage

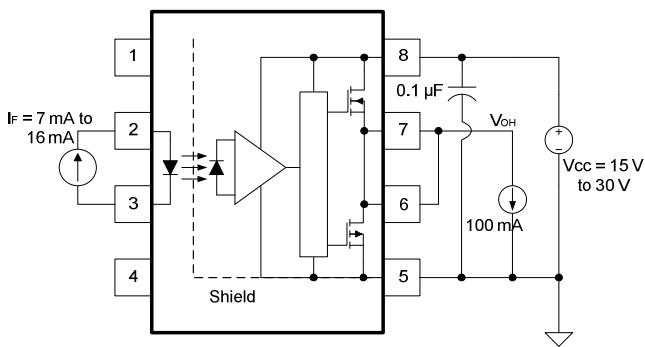

Figure 14 : V_{OH} Test Circuit

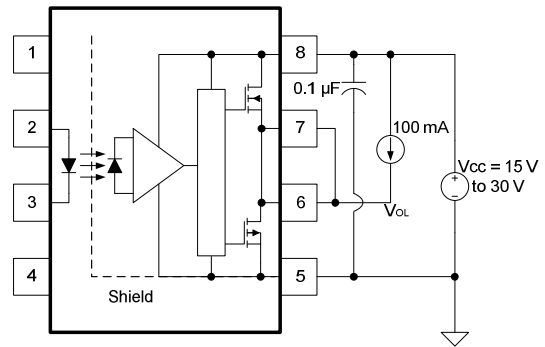

Figure 15 : V_{OL} Test Circuit

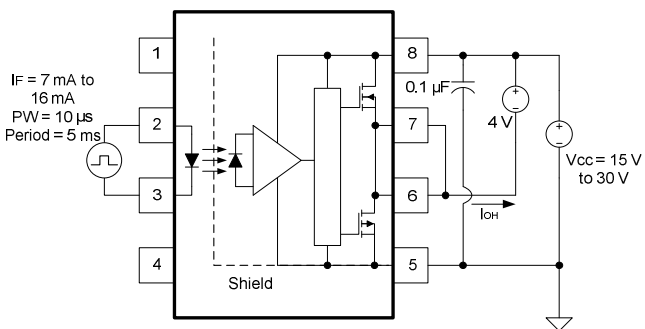

Figure 16 : I_{OH} Test Circuit

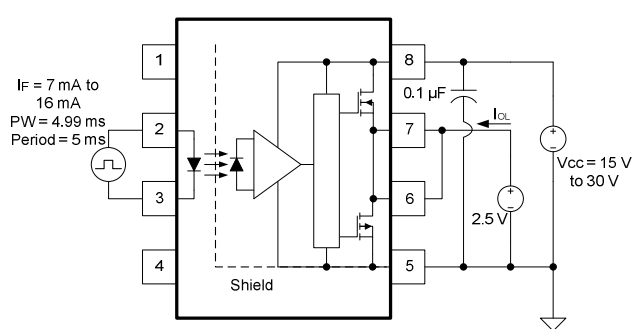

Figure 17 : I_{OL} Test Circuit

Photocouplers LTV-3150 series

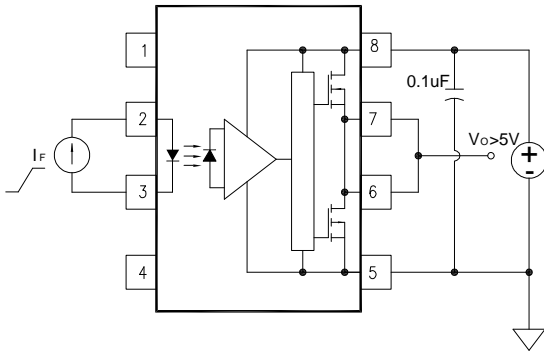

Figure 18 : IFLH Test Circuit

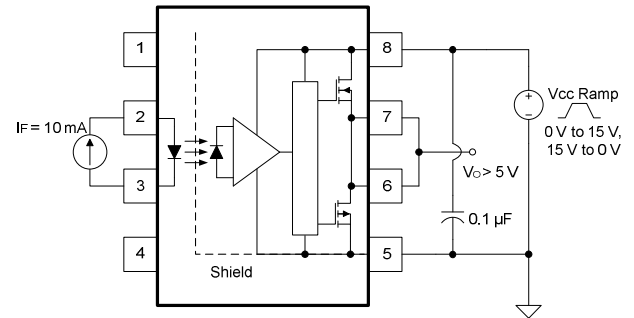

Figure 19 : UVLO Test Circuit

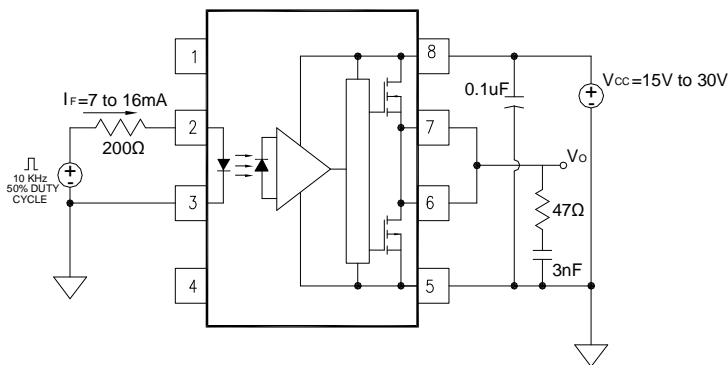

Figure 20 : t_r , t_f , t_{PLH} and t_{PHL} Test Circuit and Waveforms

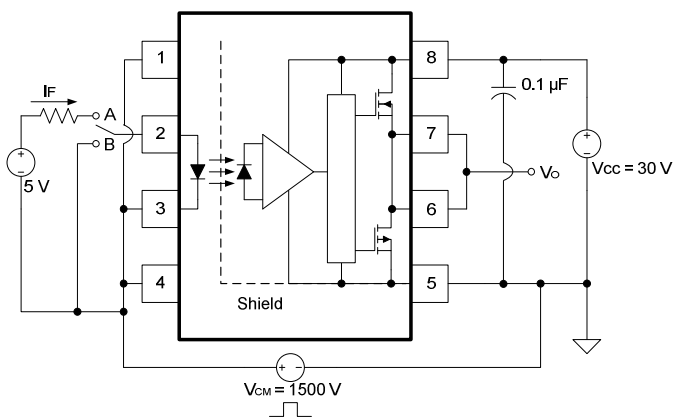
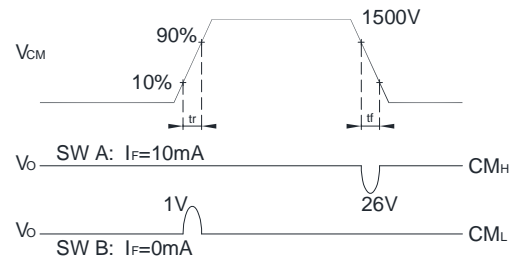

Figure 21 : CMR Test Circuit and Waveforms



Photocouplers LTV-3150 series

8. TEMPERATURE PROFILE OF SOLDERING

8.1 IR Reflow soldering (JEDEC-STD-020C compliant)

One time soldering reflow is recommended within the condition of temperature and time profile shown below. Do not solder more than three times.

Profile item	Conditions
Preheat	
- Temperature Min (T_{Smin})	150°C
- Temperature Max (T_{Smax})	200°C
- Time (min to max) (ts)	90±30 sec
Soldering zone	
- Temperature (T_L)	217°C
- Time (t_L)	60 ~ 100 sec
Peak Temperature (T_P)	260°C
Ramp-up rate	3°C / sec max.
Ramp-down rate	3~6°C / sec

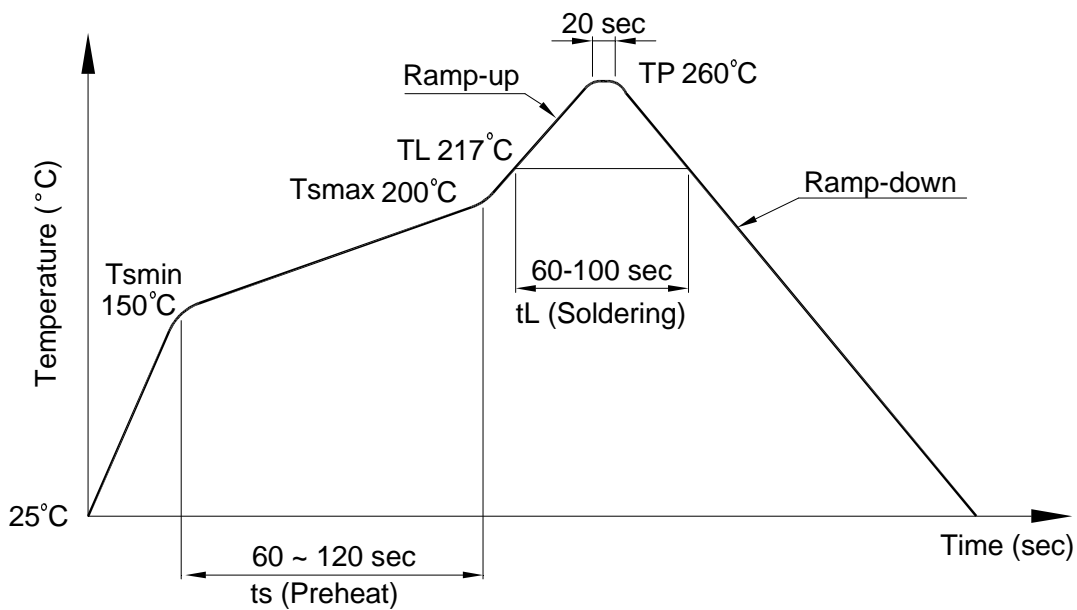

**Photocouplers
LTV-3150 series**

8.2 Wave soldering (JEDEC22A111 compliant)

One time soldering is recommended within the condition of temperature.

Temperature: $260+0/-5^{\circ}\text{C}$

Time: 10 sec.

Preheat temperature: 25 to 140°C

Preheat time: 30 to 80 sec.

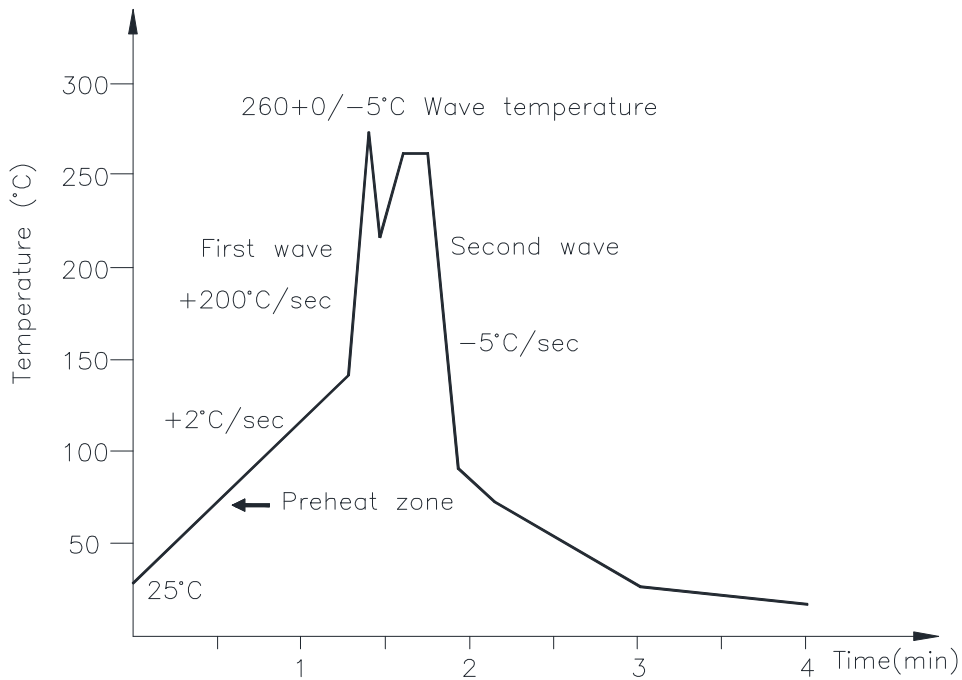

8.3 Hand soldering by soldering iron

Allow single lead soldering in every single process. One time soldering is recommended.

Temperature: $380+0/-5^{\circ}\text{C}$

Time: 3 sec max.

**Photocouplers
LTV-3150 series**

9. ORDERING INFORMATION

Part Number Options
LTV-3150
LTV-3150M
LTV-3150S-TA
LTV-3150S-TA1
LTV3150-V
LTV3150M-V
LTV3150STA-V
LTV3150STA1-V

Definition of Suffix	Remark
"3150"	LiteOn model name
"No Suffix"	Dual-in-Line package clearance distance 7 mm typical
"S"	Surface mounting package clearance distance 8 mm typical
"M"	Wide lead package clearance distance 8 mm typical
"TA1"	Pin 1 location at upper left of the tape
"TA"	Pin 1 location at lower right of the tape
"V"	VDE approved option

10. Notes:

Specifications of the products displayed herein are subject to change without notice.

The products shown in this publication are designed for the general use in electronic applications such as office automation equipment, communications devices, audio/visual equipment, electrical instrumentation and application. For equipment/devices where high reliability or safety is required, such as space applications, nuclear power control equipment, medical equipment, etc, please contact our sales representatives.