

Description and Application Manual

Six-Channel Plug-and-play SCALE IGBT Driver 6SD312EI for EconoPACK+ Modules

A compact, plug-and-play, high-performance 3-phase driver

Abstract

The 6SD312EI is a six-channel driver based on CONCEPT's proprietary SCALE chipset, a proven technology for the reliable driving and safe operation of IGBTs.

The driver is matched to EconoPACK+ IGBT modules. Its plug-and-play capability makes it ready to operate immediately after mounting. The user need invest no effort in designing or adjusting it to a specific application.

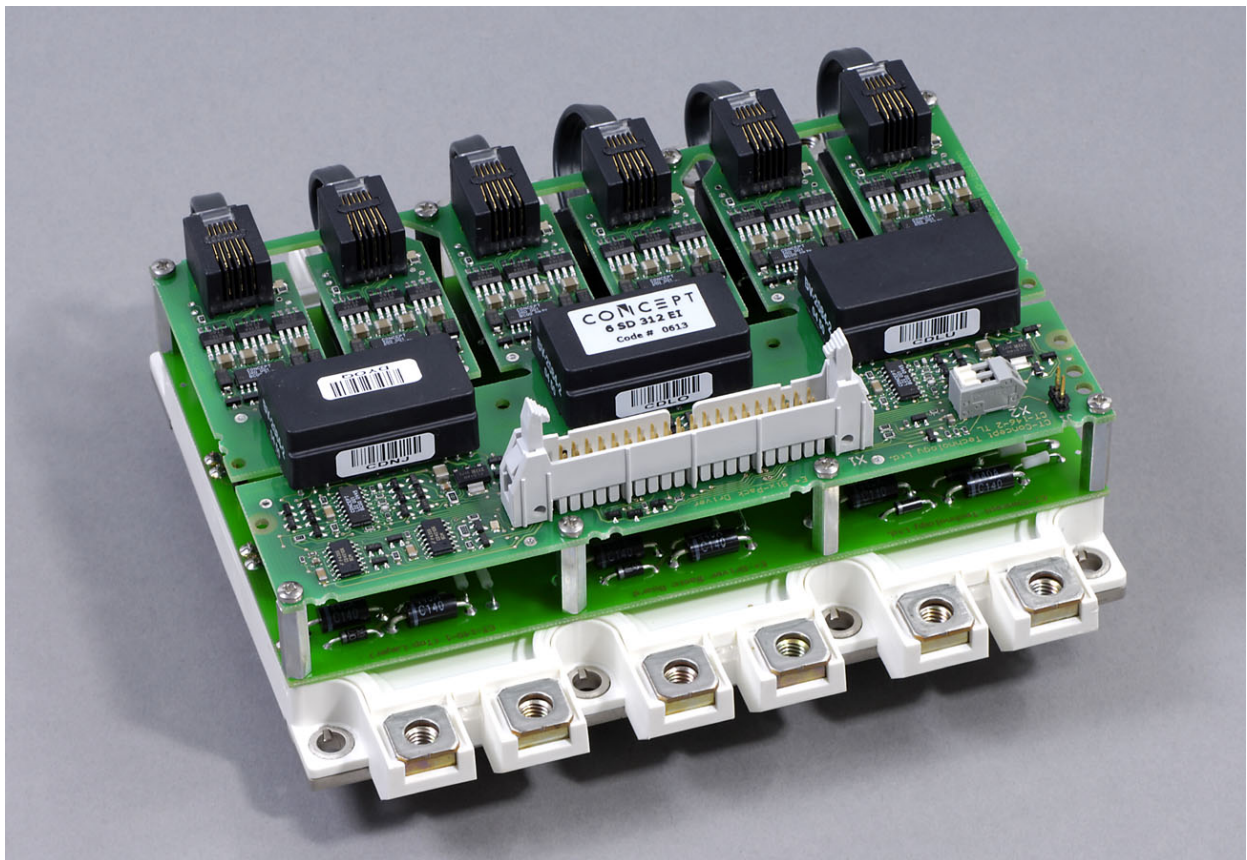

Fig. 1 6SD312EI driver and basic board mounted on an EconoPACK+ module

Description and Application Manual

Contents

System Overview	4
The Eight Steps to Success	5
1. Calculate the power dissipation of the IGBT modules	5
2. Choose a suitable driver / basic board pair	5
3. Design the power stack	5
4. Attach the drivers to the IGBT modules.....	5
5. Connect the driver to the control electronics	6
6. Select the operating mode	6
7. Check the driver function	6
8. Set-up and test the power stack	6
Pin Designation of SCALE Driver 6SD312EI	7
Pin designation of interface X1	7
Pin designation of shutdown connector X2	7
Recommended Interface Circuitry.....	8
Description of Interface X1.....	10
General.....	10
<i>VDC</i> terminals	10
<i>VDD</i> terminals	10
<i>Mod</i> (input, mode selection).....	11
<i>ResetQ</i> (input/output).....	12
<i>InA, InB</i> (six-channel drive inputs, e.g. PWM)	13
<i>SO 1 - SO 6</i> (status outputs)	13
Shutdown Connector X2 and Jumper J1	15
LED-Status Indicators.....	15
Green LEDs (channel-status indicators)	15
Red LED (reset).....	15
Basic board: The Plug-and-Play Adapter Board.....	16
Protection Concept	16
Power-supply monitoring	16
Short-circuit and overcurrent protection.....	17

Description and Application Manual

Active clamping 18

Bibliography..... 20

The Information Source: SCALE Driver Data Sheets..... 21

Quite Special: Customized SCALE Drivers..... 21

Evaluation Systems..... 21

Customer-Specific Systems 21

Consulting and Training..... 22

Technical Support 22

Quality 22

Disclaimer 22

Ordering Information 23

Manufacturer 23

Description and Application Manual

System Overview

The standard package of EconoPACK+ modules covers several voltage and current ratings (e.g. 150, 225, 300, and 450A at 1200 and 1700V). Some driver parameters must therefore be matched to the relevant module. As shown in Figs. 1 and 2, this is done by placing all specific components on a separate basic board which is completely assembled and tested by CONCEPT. (The customer must order the basic board corresponding to the relevant IGBT module.)

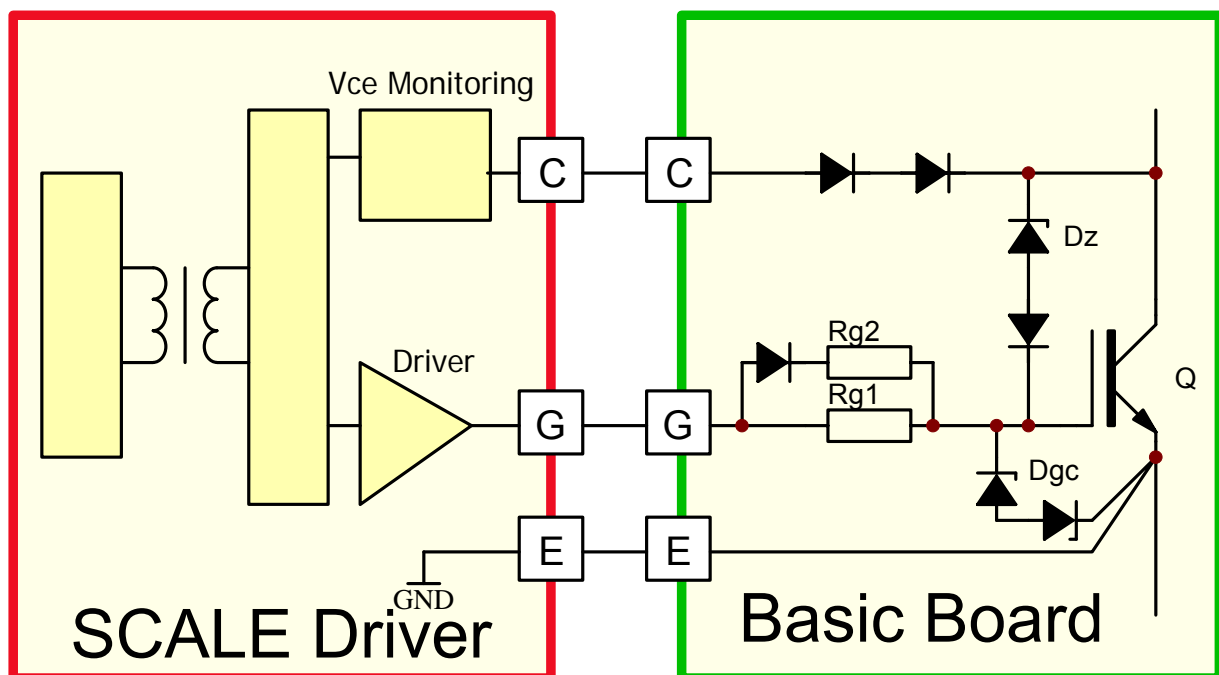

Fig. 2 Separation of universal (left) and IGBT-specific functions (right)

The basic board contains all gate resistors, gate-clamping and active-clamping diodes (overvoltage protection) as well as the diodes for the collector-sense function (surge-current and short-circuit protection). Moreover, it includes components for setting the turn-off trip level and the response time. It contains only the usual through-hole components and can consequently be easily adjusted by the user to fit any special needs and applications.

The 6SD312EI driver is a complex PCB equipped with SMD components such as CONCEPT's proprietary chipset. It is mounted on top of the relevant basic board by means of spacer bolts. The standardized 6SD312EI driver matches all modules within the EconoPACK+ series. It is based on the proven SCALE technology developed by CONCEPT and implemented more than a hundred thousand times. For further information on this technology, refer to /1/ and /2/.

Description and Application Manual

The Eight Steps to Success

The following steps point out the easy way to design high-power converters by using 6SD312EI drivers with EconoPACK+ modules:

1. Calculate the power dissipation of the IGBT modules

First choose the EconoPACK+ IGBT module suited for your application and determine its specific on-state and switching losses. This data is used to approximate the size of the required heat sink.

2. Choose a suitable driver / basic board pair

When applying 6SD312EI drivers for EconoPACK+ modules, you should note that the basic boards are specifically adapted to a particular type of IGBT module.

The type designation of the basic board consequently also includes the type designation of the corresponding module.

These basic boards are valid only for the specified IGBT modules. Neglect of this warning may lead to failure.

3. Design the power stack

When designing a power stack, be sure to minimize the parasitic inductances.

To speed-up your startup with 6SD312EI drivers for EconoPACK+ modules, CONCEPT offers ready-to-use evaluation systems; see page **Fehler! Textmarke nicht definiert.**

Some key issues relating to component selection are discussed in /4/.

4. Attach the drivers to the IGBT modules

Any handling of IGBT modules or drivers is subject to the general specifications for protecting electrostatic-sensitive devices according to international standard IEC 747-1, Chapter IX or European standard EN 100015 (i.e. the workplace, tools, etc. must comply with these standards).

If these specifications are ignored, both IGBTs and drivers may be damaged.

Description and Application Manual

The driver can be easily mounted onto an IGBT module by soldering the basic board pins. The driver is then screwed onto the basic board by means of the spacer bolts.

The connection between the SCALE driver and the basic board is made by six modular cables. Be sure to verify that the connectors are properly snapped-in.

5. Connect the driver to the control electronics

Connect the driver plug X1 to your control electronics and supply the driver with a voltage of +15V. If you have a heat sink overtemperature switch, connect it to X2 and pull out Jumper J1. Otherwise check that J1 is set.

6. Select the operating mode

The operating mode can be set with input *MOD* (interface X1: pin 37). For details, see page 11.

7. Check the driver function

Check the gate voltage: For the off-state, the nominal gate voltage is –15V. For the on-state, it is +15V. Also check the input current consumption of the driver without clock signals and at the desired switching frequency.

It is recommended that these tests be performed before installation, as the gate terminals may otherwise not be accessible.

8. Set-up and test the power stack

Before starting up the system, you are recommended to check each IGBT module separately under power-cycling conditions. It is usually sufficient to apply the single or double-pulse technique.



CAUTION: The data contained in this product description is intended exclusively for technically trained staff. Handling all high-voltage equipment involves risk to life. Strict compliance with the respective safety regulations is mandatory!

Description and Application Manual

The short-circuit behavior can now be verified.

After this step, the system is ready to start under real-world load conditions. This allows the thermal behavior of the whole arrangement to be determined.

The system must now be re-qualified over the entire specified range of temperature and load conditions.

Pin Designation of SCALE Driver 6SD312EI

Pin designation of interface X1

1	VDC Phase U (Ch1+Ch2)	2	GND
3	VDD Phase U (Ch1+Ch2)	4	GND
5	SO2 Phase U (Ch2)	6	GND
7	InB_Phase U (Ch2)	8	GND
9	SO1 Phase U (Ch1)	10	GND
11	InA_Phase U (Ch1)	12	GND
13	VDC Phase V (Ch3+Ch4)	14	GND
15	VDD Phase V (Ch3+Ch4)	16	GND
17	SO2 Phase V (Ch4)	18	GND
19	InB_Phase V (Ch4)	20	GND
21	SO1 Phase V (Ch3)	22	GND
23	InA_Phase V (Ch3)	24	GND
25	VDC Phase W (Ch5+Ch6)	26	GND
27	VDD Phase W (Ch5+Ch6)	28	GND
29	SO2 Phase W (Ch6)	30	GND
31	InB_Phase W (Ch6)	32	GND
33	SO1 Phase W (Ch5)	34	GND
35	InA_Phase W (Ch5)	36	GND
37	Input Mod (mode selection)	38	GND
39	Input/Output ResetQ	40	GND

Pin designation of shutdown connector X2

1	Shutdown
2	GND

Description and Application Manual

Recommended Interface Circuitry

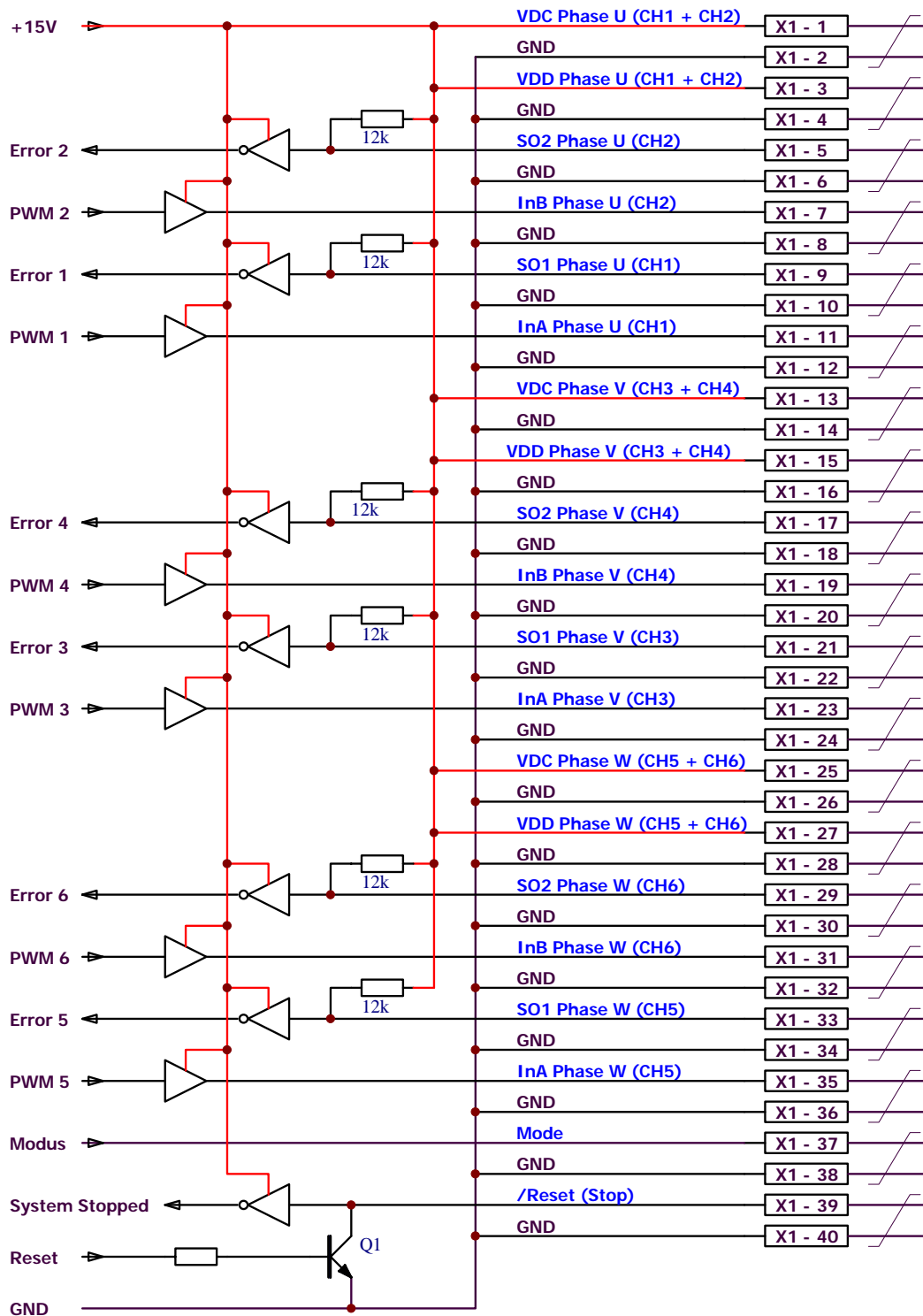

Fig. 3 Recommended user interface of 6SD312EI drivers for EconoPACK+ modules

Description and Application Manual

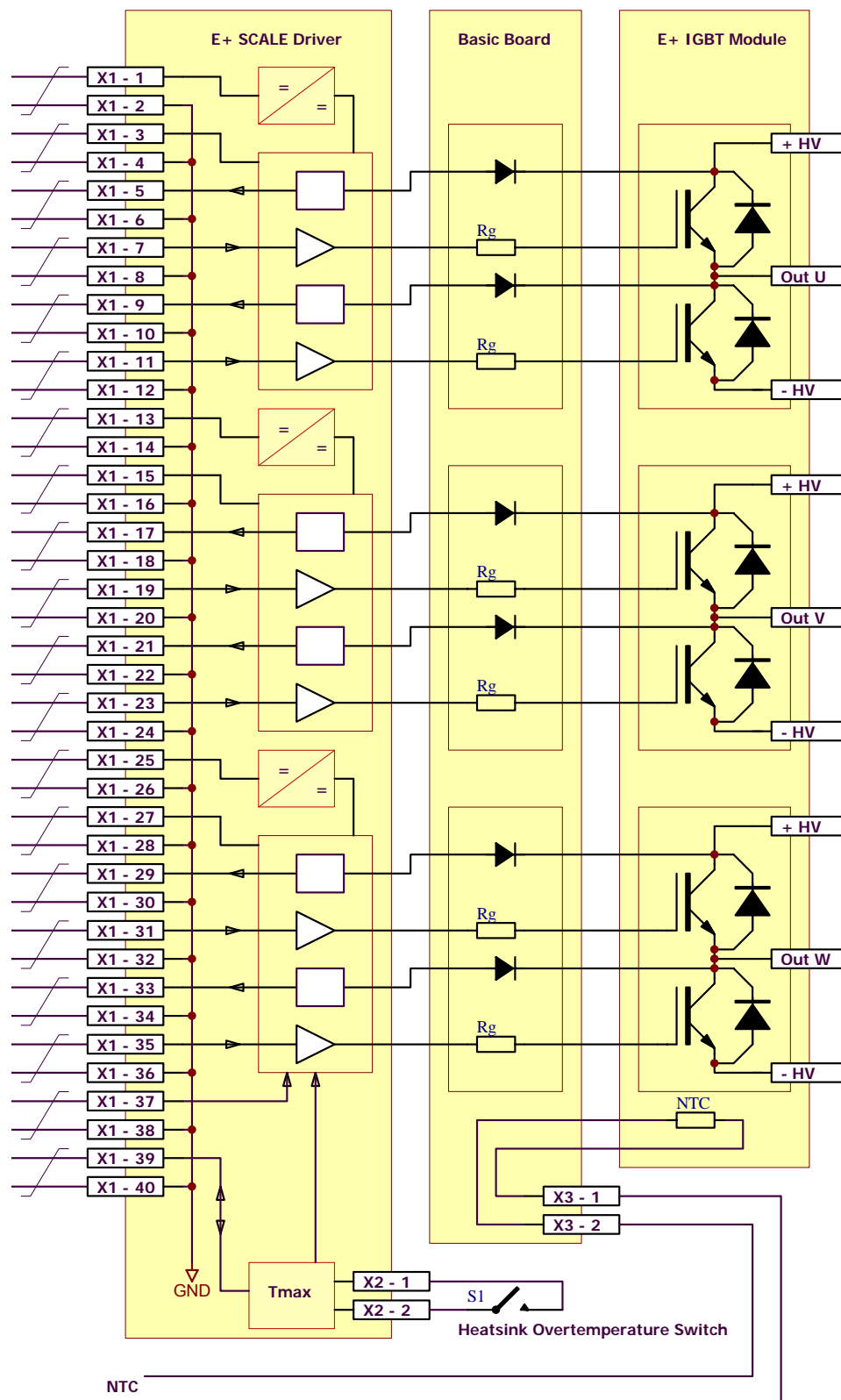

Fig. 4 Block diagram covering SCALE driver, basic board and IGBT module

Description and Application Manual

Description of Interface X1

General

The interface of the 6SD312EI driver is very simple and easy to use.

The driver has the following terminals:

- 6 x PWM inputs (drive signals)
- 6 x status outputs (failure returns)
- 6 x power-supply terminals (but only one 15V power supply is needed)
- 1 x reset input/output (bi-directional)
- 1 x mode selection (half-bridge mode / direct mode)

The driver is equipped with a 40-pin interface connector. All even-numbered pins are used as GND connections. The odd-numbered pins are used as inputs or status outputs. It is recommended to use a 40-pin twisted flat cable. Each input and output signal is then twisted with its own GND wire. All GND pins are connected together on the SCALE driver and should also be connected on the control-board side. This arrangement produces a very low-inductance connection with high immunity against interference.

For improved noise immunity, the driver's input signals have 15V levels. (The 5V operating mode of the SCALE chipset is not available for this driver.)

All inputs have Schmitt-trigger characteristics and are ESD-protected by diodes.

VDC terminals

The driver has three *VDC* terminals on the interface connector, one for each half-bridge driver. In operation, all these terminals are connected together to the common +15V voltage supply.

As the driver delivers the total power of $6 \times 3W = 18W$, the maximum input current drawn from the +15V supply is approx. 1.5A (total for all terminals *VDC* and *VDD*).

If any of the half-bridges is not in use in an application (e.g. during testing), it can be disconnected from the +15V supply to save power.

VDD terminals

The driver has three *VDD* terminals on the interface connector, one for each half-bridge driver. In normal operation, all these terminals are connected together to the common +15V voltage supply.

Description and Application Manual

All three *VDD* and all three *VDC* terminals can be connected to a single +15V power supply. A terminal is split into separate pins only for testing.

If any of the half-bridges is not in use in an application (e.g. during testing), it can be disconnected from the +15V supply to save power.

Mod (input, mode selection)

The *Mod* input allows the operating mode to be selected (applies to all driver channels).

Half-bridge mode

If input *Mod* is low (connected to GND), half-bridge mode is selected, see Fig. 5. In this mode, the inputs *InA* and *InB* have the following functions: *InA* is the PWM signal input while *InB* acts as the enable input (one *InB* per half-bridge).

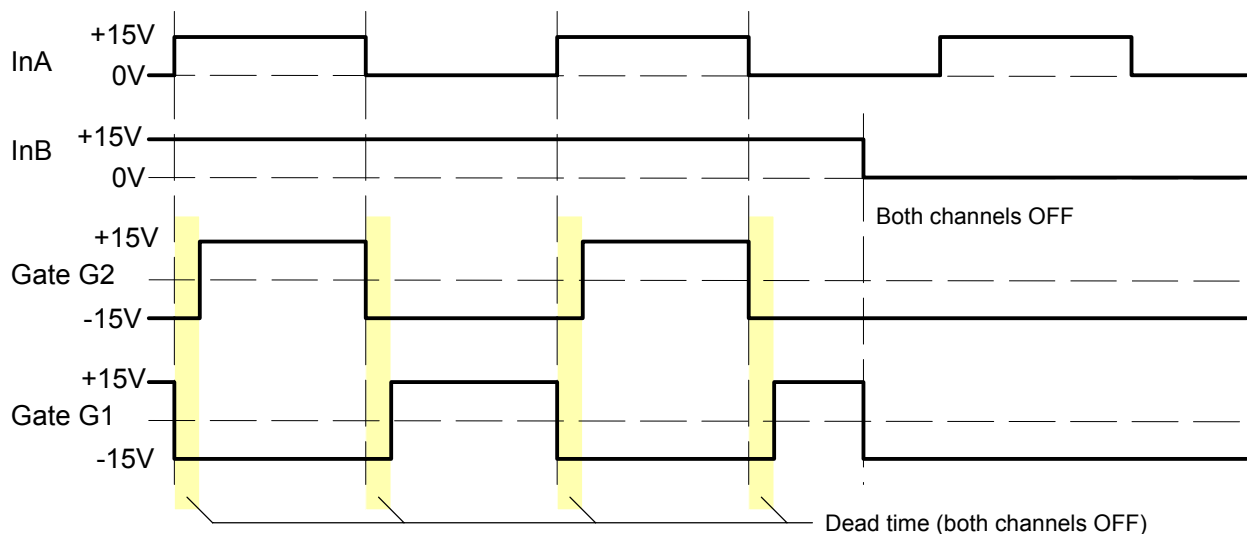

Fig. 5 Signals in half-bridge mode

When input *InB* is low, both channels of the half-bridge are blocked. If it goes high, both channels are enabled and follow the signal on the input *InA*. At the transition of *InA* from low to high, channel 1 turns off immediately and channel 2 turns on after a dead time. The dead times are set by RC networks on the SCALE driver.

Direct mode

If input *Mod* is high (connected to VDD), direct mode is selected. In this mode, there is no interdependence between the two channels in any half-bridge. Input *InA* directly influences channel 1 (low-side IGBT) while *InB* influences channel 2 (high-side IGBT). High at an input (*InA* or *InB*) always results in turn-on of the corresponding IGBT. This mode should be selected only when the dead times are generated by the control

Description and Application Manual

circuitry so that each IGBT receives its own drive signal. In this mode, both channels can be driven either synchronously or with overlapping timing (i.e. for parallel resonance converters).

Caution: Synchronous or overlapping timing of both switches of a half-bridge basically shorts the DC link.

The input *Mod* has a built-in 4k7 pull-up resistor and Schmitt-trigger characteristics.

ResetQ (input/output)

The terminal *ResetQ* is bi-directional (see Fig. 6). It has a built-in 2k2 pull-up resistor and Schmitt-trigger characteristics.

Note: The *ResetQ* terminal is optional. If not used, it can be either left open or connected via an additional pull-up resistor to VDD.

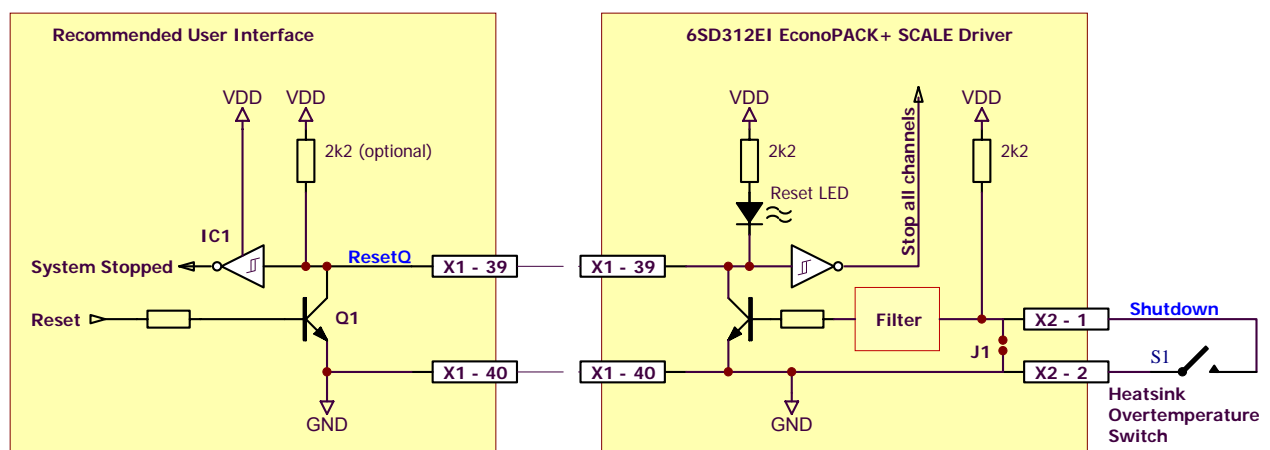

Fig. 6 Recommended user interface, terminal *ResetQ*

If the terminal *ResetQ* is pulled down (by transistor Q1) to GND, then:

- The error memory of the driver (in the interface chip LDI 001) is reset, assuming that it had been set earlier
- All six driver channels are blocked (all IGBTs are turned off)
- The red "reset LED" lights up during reset

The error memories are initially set when the SCALE driver starts up. They can be reset by temporarily connecting the input *ResetQ* to GND (after start-up, controlled by a power-up signal). An automatic reset is then applied at the first edge of the drive signals provided that the blocking time has already elapsed (on all channels). So it is recommended to wait approx. 2 seconds after connecting the supply voltage (VDD and VDC) to the driver before applying signals to the inputs *InA* or *InB*.

Description and Application Manual

When X2 is used for thermal shutdown, opening of the contact shorts terminal *ResetQ* to GND: this turns off all channels and the reset LED lights up. This process can be monitored by IC1 on the user interface. It is recommended to use a Schmitt trigger gate to ensure clean logic signals. If X2 is not used, monitoring *ResetQ* with IC1 has no effect.

***InA*, *InB* (six-channel drive inputs, e.g. PWM)**

These are basically PWM inputs, but their function depends on the *Mod* input (see above). These inputs only accept 15V logic (designed for high noise immunity). They have built-in 4k7 pull-down resistors and Schmitt-trigger characteristics.

***SO 1* - *SO 6* (status outputs)**

The outputs *SOx* have open-collector transistors (see Fig. 7). When an error condition is detected in channel "x", the output goes to low (connected to GND). Otherwise, the output has high impedance.

Any number of *SOx* outputs can be connected together to provide a common error signal (e.g. for one phase or for the whole inverter). However, it is recommended to evaluate the status signals individually to allow a fast and precise failure diagnosis.

The outputs *SOx* can be connected to the +5V...+15V power supply via a pull-up resistor (the voltage at *SOx* must not exceed the VDD level). The outputs *SOx* can handle a maximum current of 1.5 mA. To ensure a clean logic signal, it is recommended to apply a filter and a Schmitt trigger gate to *SOx*.

Description and Application Manual

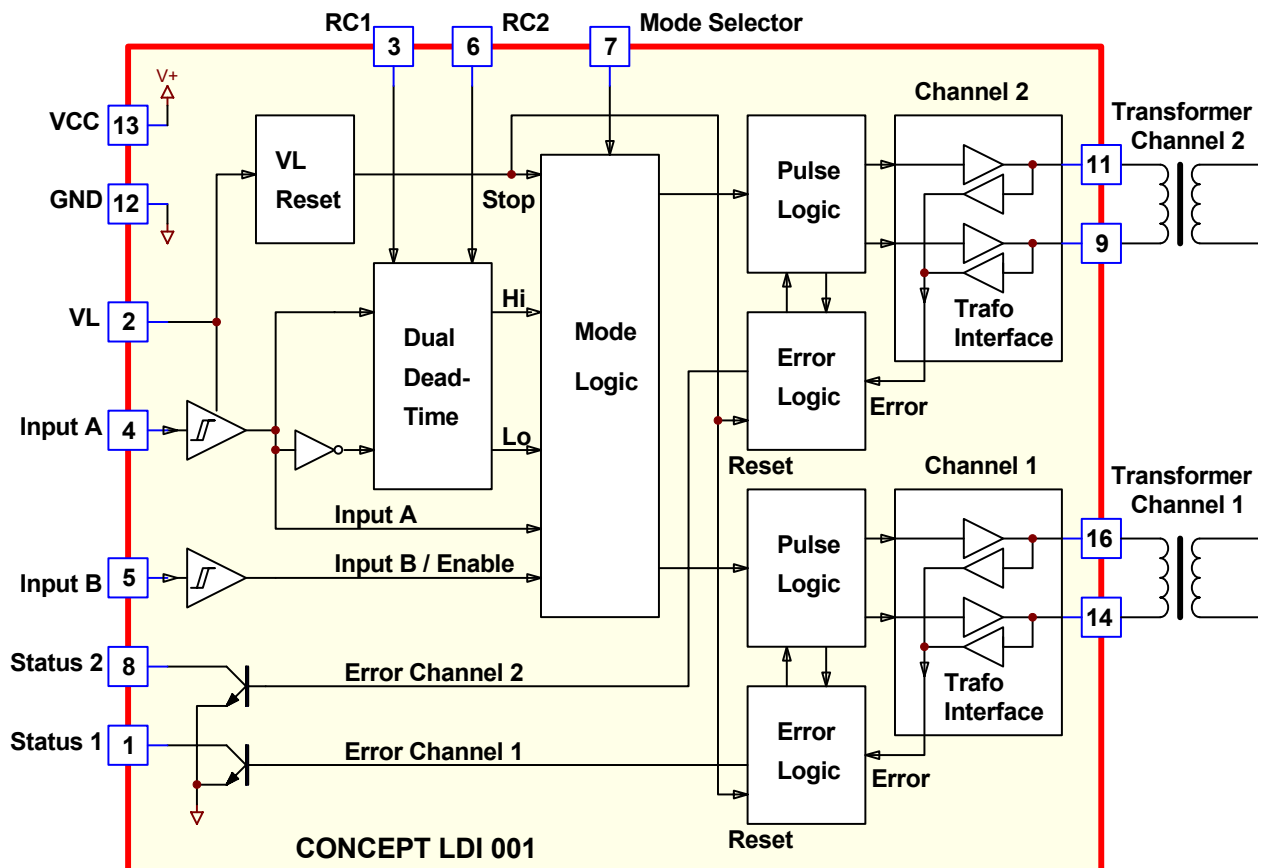

Fig. 7 Block diagram of the LDI 001

How the status information is processed

Each transition in a drive signal leads to:

- An error-memory reset of LDI 001
- Transfer of status information from IGD 001 to LDI 001
- If a failure is detected by IGD 001 (during the blocking time), the error memory in LDI 001 is set.

External reset

The error memory may also be reset by temporarily connecting the input *ResetQ* to GND. Under a failure condition, the error memory is set with the next transition of the input signal.

Description and Application Manual

Shutdown Connector X2 and Jumper J1

Connector X2 is designed to connect a heat-sink over-temperature switch. The driver is ready to use as soon as the contact is closed. An open contact means that all driver channels are turned off, a fact displayed by the re-set LED.

If X2 is not used, it is terminated with Jumper J1, which is the default. (J1 must be removed to enable the shutdown function of X2.)

LED-Status Indicators

Green LEDs (channel-status indicators)

To facilitate verification, the driver is equipped with green status LEDs (for each of its six channels.) They are located on the SCALE driver close to the output connectors (refer to Fig. 1) and light up under normal operation. A turned-off LED means that the respective channel is either inactive or is not supplied with VDC voltage. Moreover, under failure conditions, the driver is blocked for approx. 1 second, thus switching the LEDs to their off-state for the same period.

Note that verification, in particular of sporadic malfunctions, is impaired when the status outputs are connected together. It is therefore recommended to check all *SOx* signals individually and to use the information supplied by the respective status LEDs.

Red LED (reset)

The red reset LED lights up in the reset state, i.e. when terminal *ResetQ* is pulled down or when shutdown connector X2 is opened.

Description and Application Manual

Basic board: The Plug-and-Play Adapter Board

The basic board contains all gate resistors, gate-clamping and active-clamping diodes (overvoltage protection) as well as the diodes for the collector-sense function (and short-circuit protection). Moreover, it also includes components for setting the turn-off trip level and the response time.

When applying 6SD312EI drivers for EconoPACK+ modules, you should note that the basic boards are adapted to a particular type of IGBT module. The type designation of the basic board consequently also includes the type designation of the corresponding IGBT module.

These basic boards are valid only for the specified IGBT modules. Neglect of this warning may lead to failure.

The driver is adapted to EconoPACK+ IGBT modules. Its plug-and-play capability means that it is ready to operate immediately after mounting. The user need not invest any effort in designing or adjusting the driver to a specific application. The basic board contains only the usual through-hole components and can therefore be easily adjusted by the user to fit any special needs and applications.

The basic boards are assembled with the smallest possible gate resistor in order to minimize switching losses.

Protection Concept

Only a brief overview will now be given of the functions of the SCALE driver chipset used here. For further information about the chipset, refer to /1/.

Power-supply monitoring

An under-voltage monitoring circuit blocks the driver if the supply voltage drops below about 10...11V. In this case, the IGBT is driven with a negative gate voltage to keep it in the off-state. A failure condition is transmitted.

The monitoring is performed locally on each channel (integrated in the IGD 001).

Short-circuit and overcurrent protection

Each channel of a SCALE driver is equipped with a V_{ce} -monitoring circuit. The circuit is inactive during the response time applied to ensure that the IGBT is fully turned on (see Fig. 8).

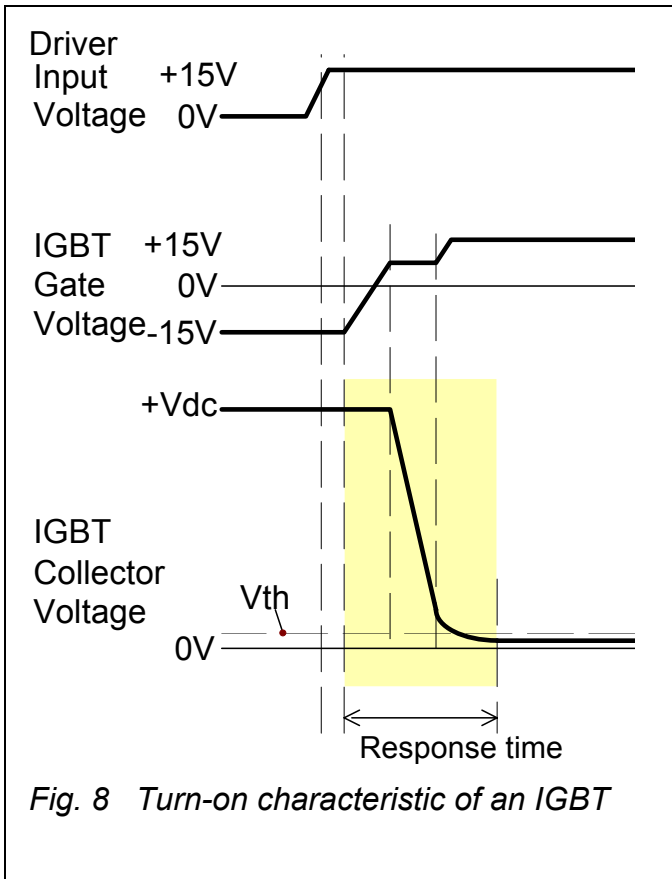

Fig. 8 Turn-on characteristic of an IGBT

In the event of failure due to V_{ce} monitoring or power-supply under-voltage lock-out, the IGBT is kept in the off-state for a blocking time during which all drive signals are ignored. The blocking time is applied independently to each channel by IGD 001. It starts when V_{ce} exceeds the threshold of the V_{ce} -monitoring circuit. With the next transition of the drive signal, the "error" information is transferred for storage to the LDI 001, whose respective status output SOx goes to low. The driver then ignores any drive signal. The error information is reset only at a first transition in the drive signal after expiry of the blocking time. This automatic reset is shown in Fig. 9. The error memories can also be reset by temporarily pulling the *ResetQ* terminal to GND.

Description and Application Manual

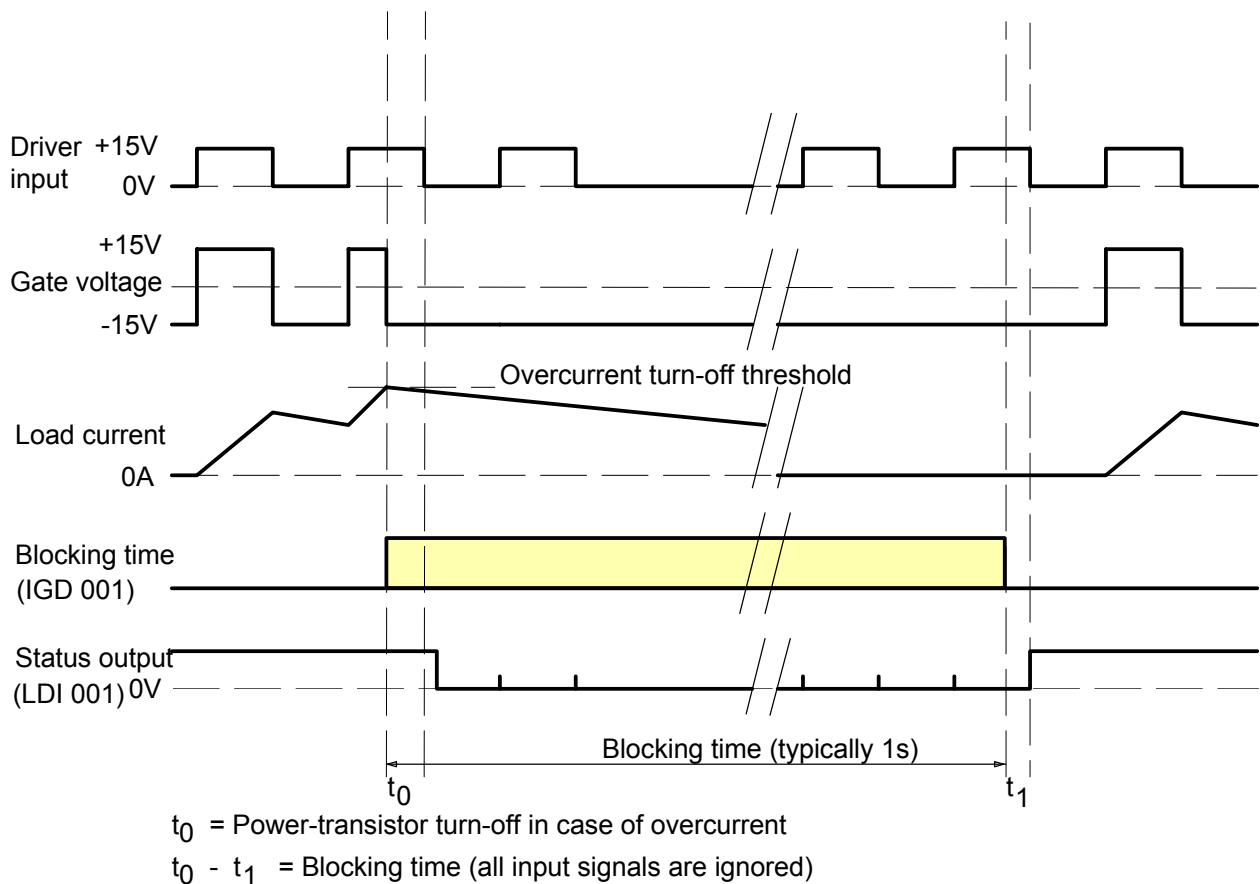

Fig. 9 Short-circuit and overcurrent protection. Automatic reset of the failure condition after expiry of the blocking time

Active clamping

Simple gate driving leads to the typical turn-off transition shown in Fig. 10. Turn-off with a specified minimum gate resistance is critical, particularly for trench-gate IGBT chips (such as those used in EconoPACK+ modules), due to the high rate of decrease of the collector current. To minimize turn-off losses, therefore, the 6SD312EI features an active clamping function. This technique is designed to turn the IGBT on partially whenever the collector-emitter voltage exceeds a predefined threshold. The IGBT is then kept in linear operation. The basic circuitry is shown in Fig. 11.

Description and Application Manual

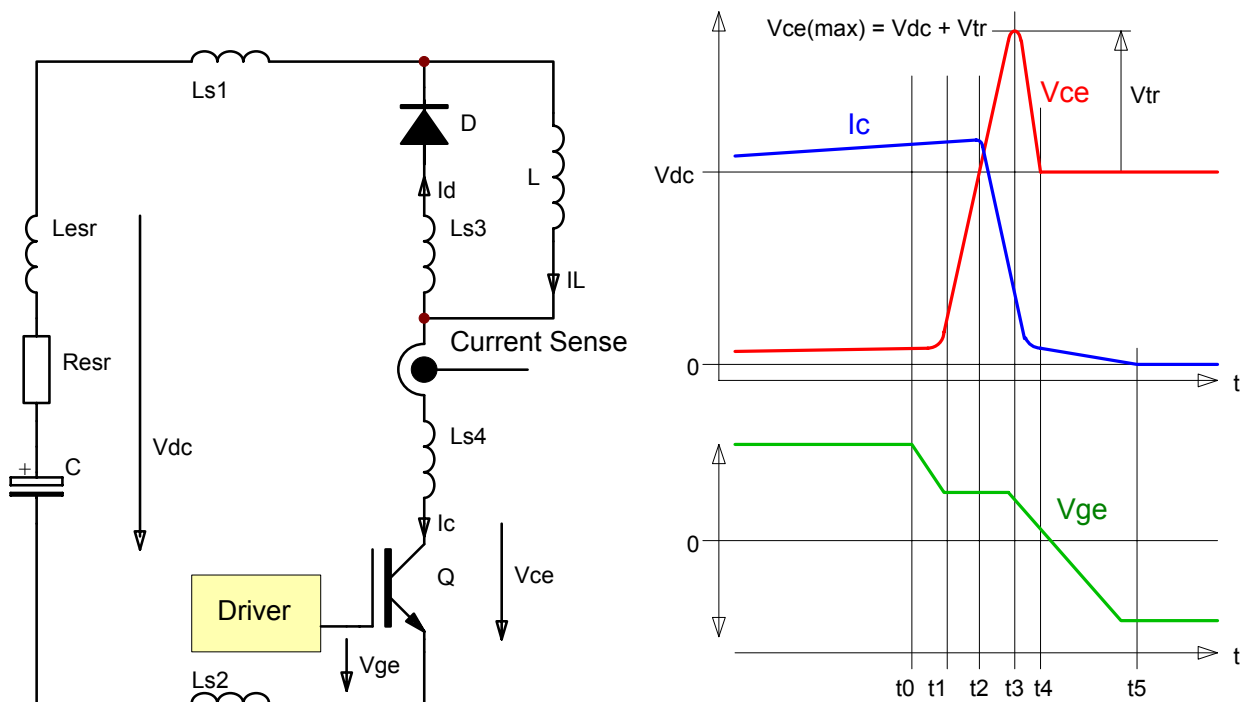

Fig. 10 Test circuit (left) and typical switching characteristics (right)

Legend to Fig. 10

- t0 = Initiation of the turn-off process
- t1 = Start of collector-emitter voltage rise
- t2 = Start of collector current drop
- t3 = Maximum collector-emitter voltage
- t4 = IGBT is blocking, start of tail current
- t5 = End of tail current

In comparison with other driving methods, active clamping allows enhanced utilization of the IGBT modules during normal operation by increasing the switching speed and thus reducing switching losses. Furthermore, active clamping manages the over-voltage under changed operating conditions.

The active clamping function should not lead the user to forget about the inductances of the power stack.

Description and Application Manual

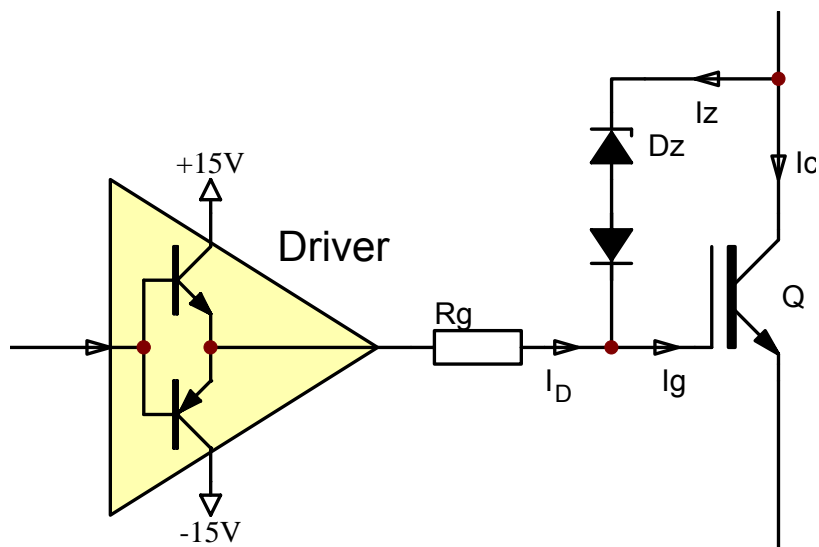

Fig. 11 Basic circuitry for active clamping

Bibliography

- /1/ Description and Application Manual for SCALE Drivers, CONCEPT
- /2/ The "SCALE" IGBT Driver, a new, scalable, compact, all purpose, low cost, easy-to-use driver for IGBTs, H. Rüedi & P. Köhli, PCIM 1998 Proceedings
- /3/ Modular SCALE Driver Solution for EconoPACK+, H. Rüedi, PCIM 2001 Proceedings
- /4/ Development of Modular High-Power IGBT Stacks, H. Rüedi & D.Tollík, PCIM 2001 Proceedings

Note: These papers are available on the Internet at www.IGBT-Driver.com/go/papers

Description and Application Manual

The Information Source: SCALE Driver Data Sheets

CONCEPT offers the widest selection of gate drivers for power MOSFETs and IGBTs for almost any application needs. The largest website on gate-drive circuitry anywhere contains all data sheets, application notes and manuals, technical information and support sections: www.IGBT-Driver.com

Quite Special: Customized SCALE Drivers

If you need an IGBT driver that is not included in the delivery range, please don't hesitate to contact CONCEPT or your CONCEPT sales partner.

CONCEPT engineers have more than 20 years experience in the development and manufacture of intelligent gate drivers for power MOSFETs and IGBTs and have already implemented a large number of customized solutions.

Evaluation Systems

The evaluation systems used with EconoDual modules are designed particularly for development, verification, qualification and testing. They contain IGBTs, driver boards and DC-link capacitors, completely mounted and 100% tested. CONCEPT offers systems with various heat sinks or without coolers.

For details see: www.IGBT-Driver.com/go/EconoPlus

Customer-Specific Systems

CONCEPT develops and produces complete power equipment and systems according to the customer's specifications.

Description and Application Manual

Consulting and Training

CONCEPT provides consulting and training services to customers on optimal procedures in power control, ideal circuit topologies as well as general do's and don'ts in the development of power electronics.

Technical Support

CONCEPT provides expert help with your questions and problems:

www.IGBT-Driver.com/go/support

Quality

The obligation to high quality is one of the central features laid down in the mission statement of CT-Concept Technology Ltd. The quality management system covers all stages of product development and production up to delivery. The drivers of the SCALE series are manufactured according to the ISO9001:2000 quality standard.

Disclaimer

This data sheet specifies devices but cannot promise to deliver any specific characteristics. No warranty or guarantee is given – either expressly or implicitly – regarding delivery, performance or suitability.

CT-Concept Technology AG reserves the right to make modifications to its technical data and product specifications at any time without prior notice. The general terms and conditions of delivery of CT-Concept Technology AG apply.

Description and Application Manual

Ordering Information

The general terms and conditions of delivery of CT-Concept Technologie AG apply.

Related IGBT	CONCEPT Driver Type #
All EconoPACK+ IGBTs	6SD312EI

Connection	CONCEPT Modular Cable Type #
6SD312EI to EB01-xxx (all types)	MIC01A (6 items per driver)

Related IGBT	CONCEPT Basic board Type #
See current list on www.IGBT-Driver.com/go/EconoPlus	

Information about Other Products

For drivers adapted to other high-voltage or high-power IGBT modules

Direct link: www.IGBT-Driver.com/go/plug-and-play

For other drivers and evaluation systems

Please click: www.IGBT-Driver.com

Manufacturer

CT-Concept Technologie AG
 Intelligent Power Electronics
 Renferstrasse 15
 CH-2504 Biel-Bienne
 Switzerland

Tel. +41 - 32 - 344 47 47

Fax +41 - 32 - 344 47 40

E-mail Info@IGBT-Driver.com

Internet www.IGBT-Driver.com

© Copyright 1998...2007 by CT-Concept Technologie AG - Switzerland.

We reserve the right to make any technical modifications without prior notice.

All rights reserved.

Version of 2007-03-19